

HAAKE®

Tapetes de Segurança



CSA SOLUÇÕES
Control Safety Automation



Protection of hazardous areas (presence and access sensing)

According to the Machinery Directive, machines may only be put into operation once comprehensive safety measures have been taken to protect the persons working with these machines. Part of these measures is the protection of hazardous areas at machines, where presence or access to running machines is to be prevented, because of the risks created by the machine.

To protect persons against risks of this kind, pressure sensitive safety mats are employed.

A safety mat belongs to the group of non-separating protective fittings with approach reaction time, which sets a machine into safe operational mode when a person approaches the area beyond the safety distance.

At devices such as machines, machining centres, presses, robot cells, high-shelf warehouses and many others, safety mats immediately switch off the power source, when the mat is stepped on.

As long as the person stays on the mat, the machine cannot be set back into operation.



Either electrically operating devices to the contact-make principle (two conductive strips or layers are brought together when the safety mat is operated), or optoelectronic systems (a light beam is interrupted) are available on the market. Such configurations need a special evaluator for transforming and processing the output signal.

The HSM® Safety Mat uses mechanical positive-break contacts. Therefore, an additional safety control unit is not needed.

Design and mode of operation of the Haake Safety Mat

As a general rule applies:

Machinery and devices presenting dangerous movements must be provided with an emergency stop device. This device is monitored by a suitable safety relay unit.

Our safety mats are built up of mechanically opening break contacts connected in series, in the form of a contact mat (see also our catalogue HSC® Safety Edges). Current conducting contact plates and insulating wedge elements are alternately lined up on an expander cord. By pre-tension, the contact plates are pressed together, and the current circuit is made. When stepping on the safety mat, at least one of the contact plate pairs is separated by action of the wedge elements, and the current circuit is broken (see fig. bottom right).

Thus, a transformation of the output signal is not required, since a circuit interruption signal is directly available.

This signal is fed to the safety relay unit already needed for the E-stop button.

This means: wiring of the contact chain is performed in identical way as that of an E-stop button.

The number of lined-up contact plates and wedge elements depends on the size of the safety mat. The contact mat is placed between rubber mats being sealed at their borders by profiles. The surface structure depends on customer's wishes or the requirements in use.

The safety mats are manufactured in the sizes as specified by each customer (max. & min. sizes see specification).

Larger protection areas are achieved by several mats connected together.

An aluminium surface trim is placed around the total mat system and is fixed to the floor (plane, clean, free from particles), in order to secure the safety mat and to avoid risks of tripping.

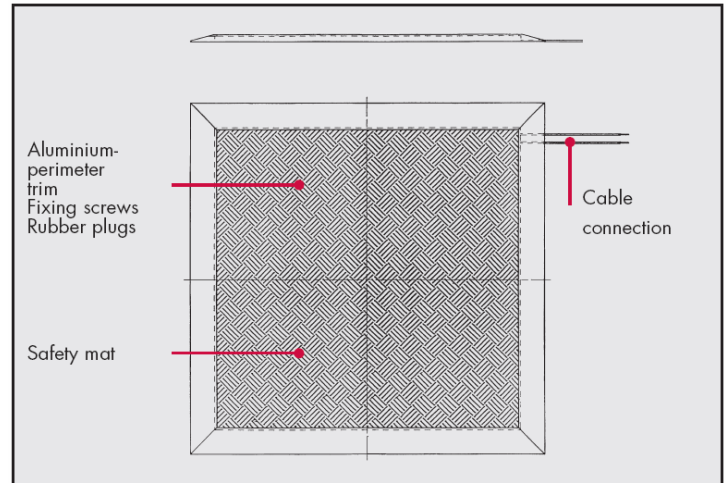

ADVANTAGE:
No Special Control Unit Needed!

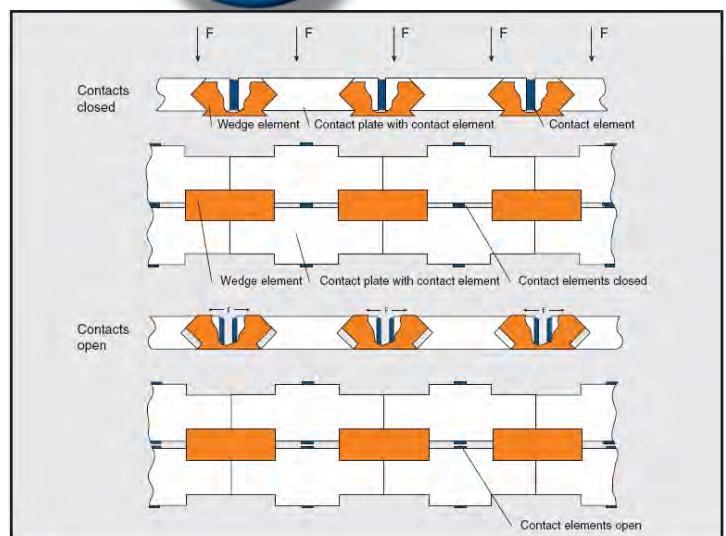

Benefits for user

A special evaluator is not required, since the contact mat is composed of electro-mechanical break contacts, the signal of which can immediately be further processed. In addition to cost saving, any expensive connection and wiring actions are unnecessary. Valuable space is won on the crowded control panel. Further, of course, a not existing device cannot break down.

Moreover, use of a break contact guarantees a high safety level. At singly occurring faults, the system immediately changes to the safe condition: it switches off.

Our safety mat meets the requirements of category 3 of EN 954-1 - even the sensor part.

Double-channel design or redundancy is not necessary for this system, since the failure mode analysis made by BG has shown: a single fault does not lead to a loss of the safety function.

This permits a simple construction of the system.



A great variety of applications for the protection of man and machine

- machining centres
- presses
- robot cells
- high-shelf warehouses
- material handling
- lifting platforms



Defined fields of use for each application

Depending on the specific applications, various conditions may occur. Please inform us, so we can select the suitable configuration.

In order to meet the specific requirements, we use polyurethane as the standard material for the mat surface.

Other materials may also be possible – please contact us.

The surface patterns may also vary from application to application. In order to prevent the risk of slipping, chequer patterns are used..

Fixing to the floor

R: aluminium ramp trim for fixing and protection against tripping (mandatory at step-on sides).

Effective increase in width: 60 – 84 mm

Standard ramp trim – R1

This ramp trim is used in applications where the cable exits are defined in the way that the cables are fed directly from the safety mat.

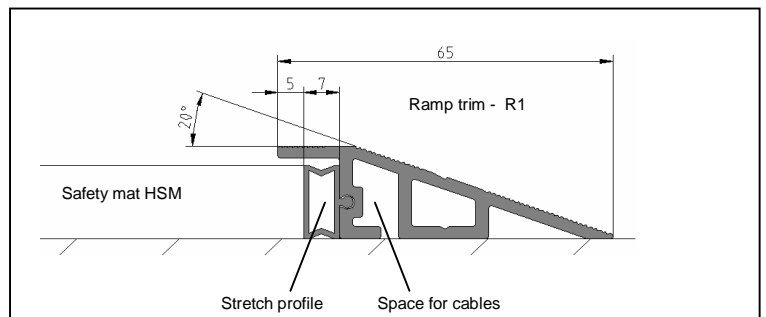

Special ramp trim – R2

This ramp trim is used for combinations of various safety mats where it is necessary to feed the cables under the ramp trim. It exists of a top and lower part and offers 30x12mm space for the cables and connections.

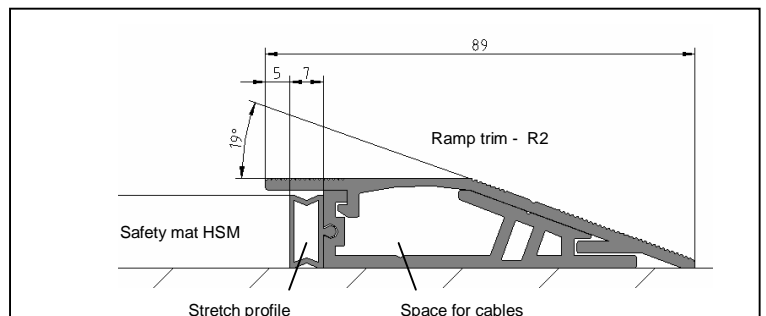

Z: angled aluminium trim for fixing only

Effective increase in width: 28 – 52 mm

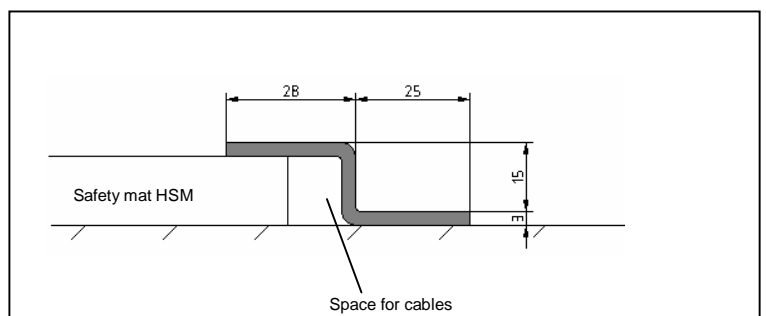

SPECIFICATION

Specification

Contact plate and wedge element of contact mat	Thermoplastic POM
Tubular rivet	E-Cu silver-plated, passivated
Expander cord	Core: Rubber Cover: woven Polyester
Aluminium ramp trim	AlMgSi0,5 extruded
Material of linings	Elastomer two-component system on PU basis Other materials on request
Surface structure	Chequer
Rated voltage / current	Max 50V AC, 75V DC max 0,5 A
Enclosure sealing	IP 54 to IEC 529/EN 60529/DIN VDE 470 pt.1
Operating temperature	+5°C ... +55°C
Cables	Standard: double insulation cables FLKM, 0,5 mm ² high flexible
Max. cable length	50 m
Admissible load	Max. 750N with test body 1 (dia. 11 mm) according to EN 1760-1 The admissible load depends on the size of the surface and should be clarified with the manufacturer
Inactive border zone	30 mm, on cable exit side 40 mm With aluminium ramp trim another 60 to 84mm
Min. mat size	Width approx. 60 mm, length approx. 50 mm
Max. mat size	Width approx. 1,000 mm, length approx. 2,000 mm
Response time	Typically less than 21 ms
Height of mat	15 mm (without aluminium ramp trim)
Weight	Approx. 18 kg/m ² (without aluminium ramp trim)
Application	Indoor use only

Warning:

In any case, starting, braking, turning of wheel-mounted vehicles on the mat surface should be prevented.

Company : _____

Name : _____

Address : _____

Phone : _____

Fax : _____

Quantity : _____ **Requested delivery time :** _____

Application : _____

1. Dimensions of active surface and position of cable exit

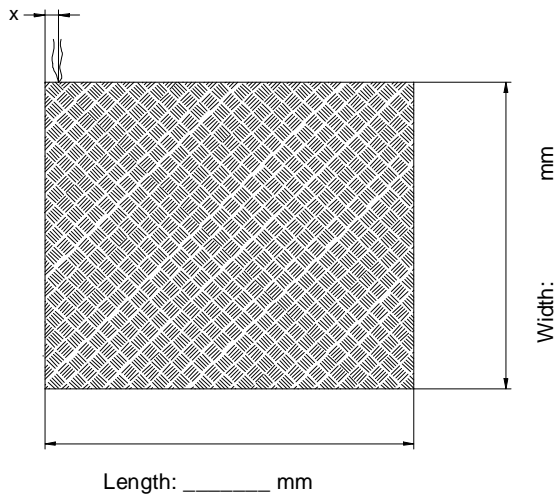

x – dimension cable exit / border:

- standard 50 mm
 customer's wish: _____ mm

Cable length:

- customer's wish _____ mm
 (up to 2,000 mm standard)

dimensions:

length (L) x width (B): _____ x _____ mm

2. Type and position of aluminium perimeter trim

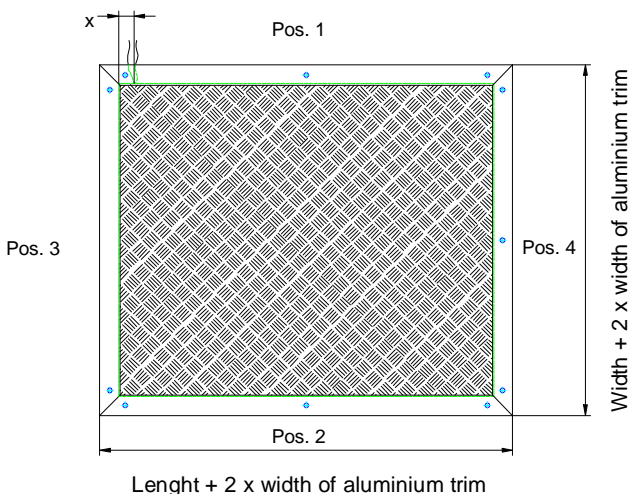

Aluminium ramp trim standard (R1):

width: 65 mm, effective additional width 60 mm

Aluminium ramp trim special (R2):

width: 89 mm, effective additional width 84 mm

Aluminium Z trim (Z):

width: 53 mm, effective additional width 28 - 52 mm

	R1	R2	Z
<u>Pos. 1</u>	<input type="checkbox"/>	<input type="checkbox"/>	<input type="checkbox"/>
<u>Pos. 2</u>	<input type="checkbox"/>	<input type="checkbox"/>	<input type="checkbox"/>
<u>Pos. 3</u>	<input type="checkbox"/>	<input type="checkbox"/>	<input type="checkbox"/>
<u>Pos. 4</u>	<input type="checkbox"/>	<input type="checkbox"/>	<input type="checkbox"/>

If not stated otherwise, fixing holes are dimensioned by us and their number is determined corresponding to the dimensions.

Fixing material (screws, dowels, plugs) is supplied with the mat.