

Linking your system

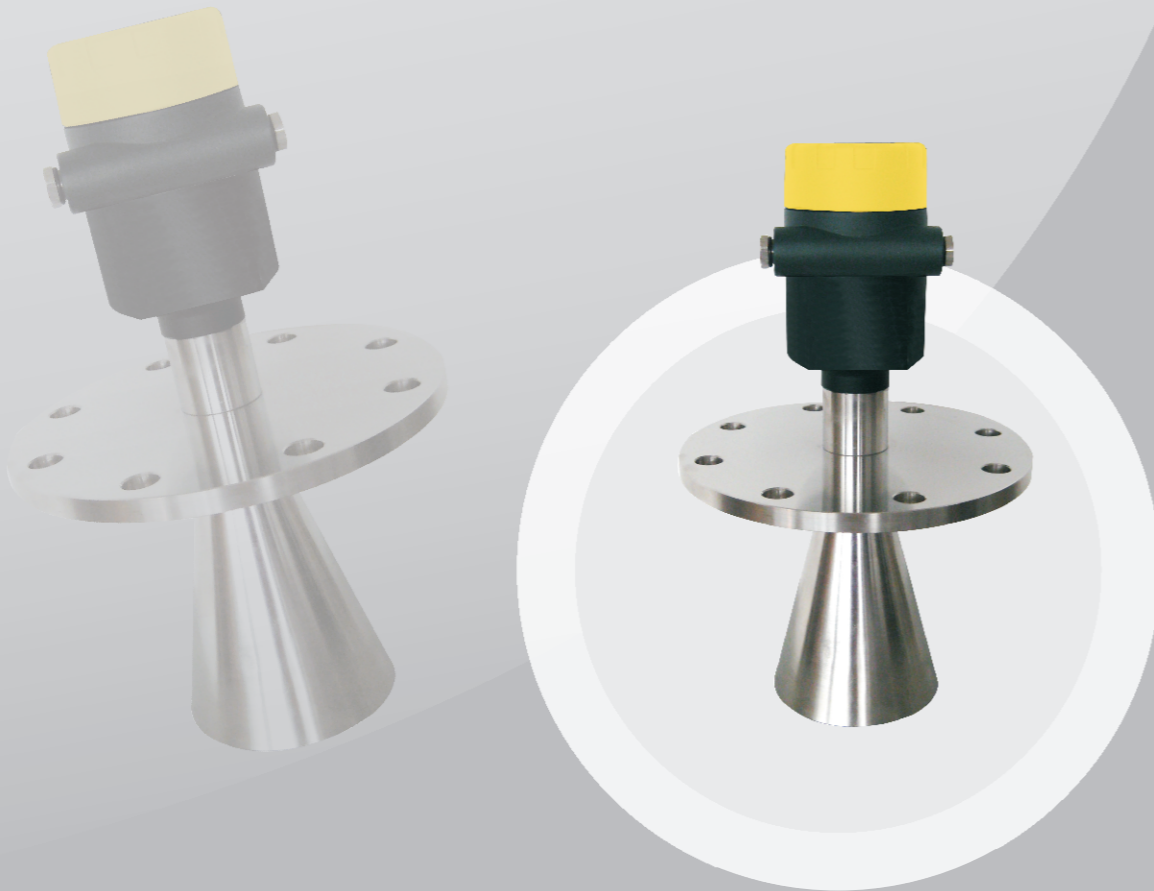

Product Features



- Wide measuring range, high precision
- Non-contact measurement, suitable for complicated working places
- Able to detect solid, liquid
- Suitable for sticky liquid, circumstance of changes in temperature and pressure
- Two wire 4 - 20 mA and analogue output
- Support HART protocol
- The max. detecting range up to 70m

Operating principle

Radar wave level transmitter is based on the principle of "verticle view" measurement system, suitable for measuring the distance between measuring reference point(process connection) and material surface. The antenna transmitting microwave pulse signal and the signal reflected in material surface, and received by radar system, then the signal transmit to the electric devices. The microprocessor deal with the signal, and identify the microwave pulse signal produced by echo in the material surface.

The distance D between refernce point and material surface in proportion to the runtime of pulse signal

$$D = c \cdot t / 2$$

C is equal to speed of light

Tank height E is known so the material level is:

$$L = E - D$$

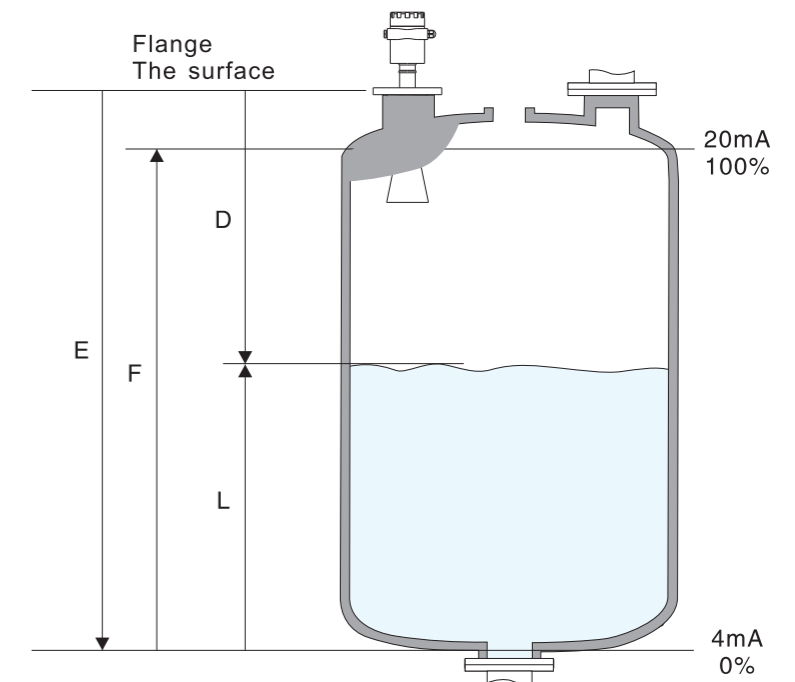

Advantages and main applications

Advantages:

- 2 wire technology: Good substitute pressure differential instruments and balancing float. 2 wire technology effectively help reduce cost of arrangement of wire, easy to relize compatible with existing systems.
- Non-contact measuring process Measurement will not be effected by medium

Main applications:

- level measurement
- Distance measurement
- Storage indication
- Differential level measurement
- Water pump control

Radar Wave Level Sensors



Smart radar level transmitter is suitable for continuous, non-contact level measurement, analogue output 4...20MA, 2 wire, suitable for storage tanks, vessels, process vessels, etc. Suitable for complicated working places such as whatever changes in temperature, pressure, medium, steam, etc.



www.ema-electronic.com

Wiring:

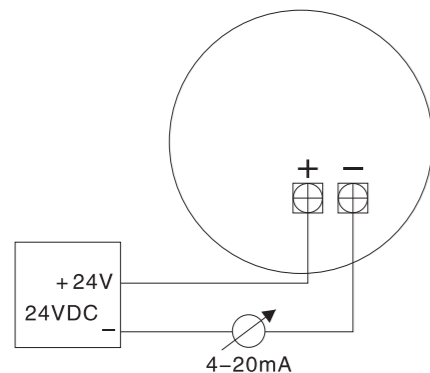

Notice:

- If the shape of tank bottom is cone or hollow, it can not be measured below the level of material when it is lower than the upper point of the fillister. (Suggestion: Set the "0 point" at the upper point of anomalous part.)
- The maximum value of measuring range should be greater than 100mm from the top of antenna in order not to affect the measurement by the corrosive media or the attachment to antenna.
- The minimum measured distance is related to the antenna.
- Foam can either absorb the microwave or reflect against the foam surface; therefore it is possible to measure the distance under certain conditions.
- When the value is over the measuring range, the output of the device indicates 22mA.

HART programming

When using the software, connect radar wave level switches with 24VDC voltage, and then to connect a 250Ohm resistance at the front end of the HART at the same time. If you use an integrated HART (internal resistance is 250 Ohm), additional resistance is unnecessary. HART adapter can be parallel connected with 4...20mA wire.

Antenna size comparison table

	a	b	nxd
DN80	200	160	8x18
DN100	220	180	8x18
DN125	250	210	8x18
DN150	285	240	8x22
DN200	340	295	12x22
DN250	405	355	12x26

C	H1
Φ76	227
Φ96	288
Φ121	620

Dimensions (mm)	RCSA	RCSB
Model	RCSA	RCSB
Product Type	Plastic probe	Antenna
Connection	G1½", 1½"NPT, Flange	
Cable Connection	M20 × P1.5, ½NPT	
Measuring Range(M)	10	30
Output(mA)	4-20/HART (2 wire/4wire)	
Launch Frequency(GHz)	26	
Power Supply(V)	24VDC, 220VAC	
Current Consumption (mA)	< 22.5	
Accuracy(mm)	±5	±3
Operating Temperature(°C)	-40~120	-40~250
Operating Pressure(Mpa)	-0.1~0.3	-0.1~4.0
Ambient Temperature(°C)	-40~80	
Ambient Pressure	Normal atmospheric pressure	
Protection Rating	IP67	
Antenna Material	PTFE	Stainless Steel 304, 316
Housing Material	Aluminum Alloy	

Radar Wave Level Sensors
Guided Radar (TDR)
Ultrasonic Level Sensors
Rotating Paddle Level Sensors
Vibrating Fork Level Switches
Float Level Switches
Capacitive Level Switches

Dimensions (mm)			
Model	RCSC	RCSD	RCSE
Product Type	Antenna		
Connection	G1½", 1½"NPT, Flange		
Cable Connection	M20×P1.5, ½NPT		
Measuring Range(M)	70	70	30
Output(mA)	4~20/HART (2 wire/4wire)		
Launch Frequency(GHz)	26		
Power Supply(V)	24VDC, 220VAC		
Current Consumption (mA)	< 22.5		
Accuracy(mm)	±15	±15	±10
Operating Temperature(°C)	-40~250		
Operating Pressure(Mpa)	-0.1~4. 0	-0.1~4. 0	Normal atmospheric pressure
Ambient Temperature(°C)	-40~80		
Ambient Pressure	Normal atmospheric pressure		
Protection Rating	IP67		
Antenna Material	Stainless Steel 304, 316		
Housing Material	Aluminum Alloy		

Order Information

RC	S	A	01	1	1	S	1	Y
Series	Housing material	Antenna type	Connection	Length of antenna tube	Cable connection	Process temperature	Cable entrance	Display
RCSA,RCSF		Application: suitable for strong corrosive liquid.Max.sensing range is 10-20M.						
RC	Radar Wave Level Sensors ,26GHz							
S	Housing protection classification S:Standard (Non-Ex-proof),Aluminium,IP67 E:EX (Exia IIC T6 Gb),Aluminum,IP67							
A	Antenna type / Material / Length A:Sealed probe , PVDF , 138mm							
01	Process connection / Material 01: Thread G1½"A 02: Thread 1½"NPT 03: FlangeDN50/PP 04: FlangeDN80/PP 05: FlangeDN100/PP							
1	Length of antenna tube 01: 100mm 02: 200mm							
1	Cable connection 1: Two wire 4~20mA 2: Two wire 24V DC/4~20mA/HART 3: Four wire 24V DC/4~20mA/HART 4: Four wire 220V DC/4~20mA/HART							
S	Seal/Process temperature S: Standard seal/-40~120°C / -40~320°C							
1	Cable entrance: 1: M20x1.5 2: ½NPT							
Y	On-site display: Y:With display							

Notice:

1. Flange execution standard reference to GB/T9119:2000, ISO7005-1:1992, dimension PN1.6MPa, thickness 10mm
2. The length of antenna should be extended at least 10mm in the tank.
3. If detecting strong corrosive liquid, it is better to choose RCSA/RCSF omniseal antenna(it is better than RCSE)
4. If RCSA measuring range is 0-10M, it is better to choose antennaΦ45, 10-20M chooseΦ75mm.

Radar Wave Level Sensors
Guided Radar (TDR)
Ultrasonic Level Sensors
Rotating Paddle Level Sensors
Vibrating Fork Level Switches
Float Level Switches
Capacitive Level Switches

Order Information

RC	S	B	05	A	4	1	S	1	Y	
Series	Housing material	Antenna type	Process connection	Antenna diameter	material	Cable connection	Process temperature	Cable entrance	Display	Accessories
RC	Radar Wave Level Sensors ,26GHz									
S	Housing protection classification S:Standard (Non-Ex-proof),Aluminium,IP67 E:EX (Exia IIC T6 Gb),Aluminum,IP67									
B	Antenna type B: Horn shape									
05	Process connection / Material Suitable for horn shape 01: Stainless steel thread G1½"A 02: Stainless steel thread 1½ NPT 03: Stainless steel flange DN50 PN1.6C type 04: Stainless steel flange DN80 PN1.6C type 05: Stainless steel flange DN100 PN1.6C type 06: Stainless steel flange DN125 PN1.6C type 07: Stainless steel flange DN150 PN1.6C type 08: Stainless steel flange DN200 PN1.6C type									
A	Antenna diameter: A: Stainless steel horn antenna Φ76mm B: Stainless steel horn antenna Φ96mm C: Stainless steel horn antenna Φ121mm									
4	Antenna and flange material: 4: Stainless steel 304 6: Stainless steel 316									
1	Cable connection 1: Two wire 4~20mA 2: Two wire 24V DC/4~20mA/HART 3: Four wire 24V DC/4~20mA/HART 4: Four wire 220V DC/4~20mA/HART									
S	Seal/Process temperature S: Standard seal / Viton/-40~150°C/-40~302°F H: High temperature seal / Kalrez /-40~250°C/-40~482°F									
1	Cable entrance 1: M20x1.5 2: ½NPT									
Y	On-site display Y:With display									
P	Accessories P: Dust cover T: PTFE / Teflon anti-corrossion coating (flange and aerial)									

- Notice:**
 1. Flange execution standard reference to GB/T9119:2000、ISO7005-1:1992, dimension PN1.6MPa, thickness 10mm
 2. If RCSB measuring range is 0-20M, it is better to choose antenna Φ76mm, 10-30M choose Φ96mm

Order Information

RC	S	C	05	B	4	1	S	1	Y	
Series	Housing material	Antenna type	Process connection	Antenna diameter	material	Cable connection	Process temperature	Cable entrance	Display	Accessories
RC	Radar Wave Level Sensors ,26GHz									
S	Housing protection classification S:Standard (Non-Ex-proof),Aluminium,IP67 E:EX (Exia IIC T6 Gb),Aluminum,IP67									
C	Antenna type C: Horn D: Paraboloid type aerial									
05	Process connection / Material 01: Stainless steel thread G1½"A 02: Stainless steel thread 1½ NPT 03: Stainless steel flange DN50 PN1.6C type (DN50 only suitable for parabolic antenna) 04: Stainless steel flange DN80 PN1.6C type 05: Stainless steel flange DN100 PN1.6C type 06: Stainless steel flange DN125 PN1.6C type 07: Stainless steel flange DN150 PN1.6C type 08: Stainless steel flange DN200 PN1.6C type 09: Stainless steel flange DN250 PN1.6C type 10: Stainless steel universal flange DN80 PN1.6C type 11: Stainless steel universal flange DN100 PN1.6C type 12: Stainless steel universal flange DN125 PN1.6C type 13: Stainless steel universal flange DN150 PN1.6C type 14: Stainless steel universal flange DN200 PN1.6C type 15: Stainless steel universal flange DN250 PN1.6C type									
B	Antenna diameter: suitable for universal adapter A: Stainless steel horn antenna Φ76mm B: Stainless steel horn antenna Φ96mm C: Stainless steel horn antenna Φ121mm suitable for parabolic antenna D: Stainless steel parabolic antenna Φ196mm E: Stainless steel parabolic antenna Φ242mm									
4	Antenna and flange material: 4: Stainless steel 304 6: Stainless steel 316									
1	Cable connection 1: Two wire 4~20mA 2: Two wire 24V DC/4~20mA/HART 3: Four wire 24V DC/4~20mA/HART 4: Four wire 220V DC/4~20mA/HART									
S	Seal/Process temperature S: Standard seal / Viton/-40~150°C/-40~302°F H: High temperature seal / Kalrez /-40~250°C/-40~482°F									
1	Cable entrance 1: M20x1.5 2: ½NPT									
Y	On-site display Y:With display									
P	Accessories P: dust cover T: With the function of sweeping									

- Notice:**
 1. Flange execution standard reference to GB/T9119:2000、ISO7005-1:1992, dimension PN1.6MPa, thickness 10mm
 2. If RCSC measuring range is 0-10M, it is better to choose antenna Φ76mm, 10-20M choose Φ96mm, 20-40M choose Φ121mm
 3. If RCSD measuring range is 40-50M, it is better to choose antenna Φ196mm, 50-60M choose Φ242mm

Radar Wave Level Sensors
Guided Radar (TDR)
Ultrasonic Level Sensors
Rotating Paddle Level Sensors
Vibrating Fork Level Switches
Float Level Switches
Capacitive Level Switches

Order Information

RCSE	Application: Suitable for solid, normal pressure and temperature tanks. Max.sensing range is 30M									
RC	S	E	01	B	4	1	S	1	Y	
Series	Housing material	Antenna type	Process connection	Antenna diameter	material	Cable connection	Process temperature	Cable entrance	Display	Accessories
RC	Radar Wave Level Switch ,26GHz									
S	Housing protection classification S:Standard (Non-Ex-proof),Aluminium,IP67 E:EX (Exia IIC T6 Gb),Aluminum,IP67									
E	Antenna type E: Horn antenna									
01	Process connection / Material					08: Stainless steel flange DN250 PN1.6C type 09: Stainless steel universal flange DN80 PN1.6C type 10: Stainless steel universal flange DN100 PN1.6C type 11: Stainless steel universal flange DN125 PN1.6C type 12: Stainless steel universal flange DN150 PN1.6C type 13: Stainless steel universal flange DN200 PN1.6C type 14: Stainless steel universal flange DN250 PN1.6C type				
	01: Stainless steel thread G1½"A 02: Stainless steel thread 1½ NPT 03: Stainless steel flange DN80 PN1.6C type 04: Stainless steel flange DN100 PN1.6C type 05: Stainless steel flange DN125 PN1.6C type 06: Stainless steel flange DN150 PN1.6C type 07: Stainless steel flange DN200 PN1.6C type									
B	Antenna diameter: A: Stainless steel horn antenna Φ76mm B: Stainless steel horn antenna Φ96mm C: Stainless steel horn antenna Φ121mm									
4	Antenna and flange material: 4: Stainless steel 304 6: Stainless steel 316									
1	Cable connection 1: Two wire 4~20mA 2: Two wire 24V DC/4~20mA/HART 3: Four wire 24V DC/4~20mA/HART 4: Four wire 220V DC/4~20mA/HART									
S	Seal/Process temperature S: Standard seal / Viton/-40~150°C/-40~302°F H: High temperature seal / Kalrez /-40~250°C/-40~482°F									
1	Cable entrance 1: M20x1.5 2: ½NPT									
Y	On-site display Y:With display									
P	Accessories P: Dust cover T: With the function of sweeping									

Notice:
1. Flange execution standard reference to GB/T9119:2000、ISO7005-1: 1992, dimension PN1.6MPa, thickness 10mm.
2. If RCSB measuring range is 0-10M, it is better to choose antenna Φ76mm, 10-20M choose Φ96mm, 10-30M choose Φ121mm,

Installation Requirements

Basic Requirements

When the antenna launch radar wave, there must be a beam angle between the lower part of antenna and the surface of material. In addition, there must be on obstacles around wave-launching area. Processing "Spurious wave reflection learning" if necessary, please also avoid the microwave and material flow crossing. While installing the device, notify that highest level should not be within inactive area. It should be kept a distance from the wall of tank. The device must be vertical toward the measured surface as possible. RA Series Radar Wave Level Transmitter is certified of Exd II CT6. When carrying out installation in hazardous area, please make sure that it must be grounded. It is necessary to follow the national's installation regulations of hazardous area by the experienced specialists. The housing of explosive-proof type radar wave level switch is made by cast-aluminum.

Notice there must be 200mm between the device and the tank.
(The frequency of radar wave is 26(GHz))

1. The surface
2. The center of tank or axis of symmetry

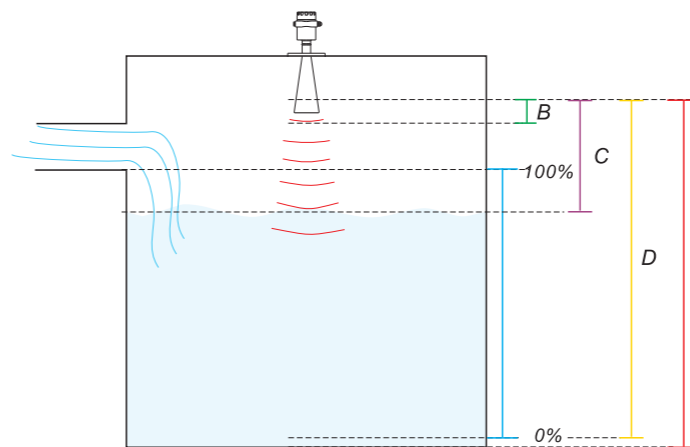

Requirement for the installation on the tank

Vessel Nozzles

Length of vessel nozzles
The length of antenna should be extended at least 10mm in the tank.
When the length of antenna is shorter than the tank fitting, it is necessary to be added the antenna extension.

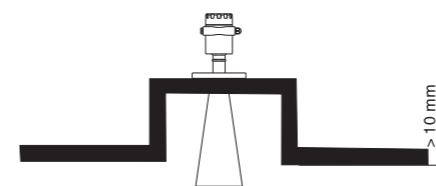

If the media with good reflection properties, the tank nozzle can be slight extend below the antenna. The standard length of the tank nozzle suggested in the table below. Under such circumstance, the end of nozzle must be smooth. Furthermore, the device may have to process "Spurious wave reflection learning".

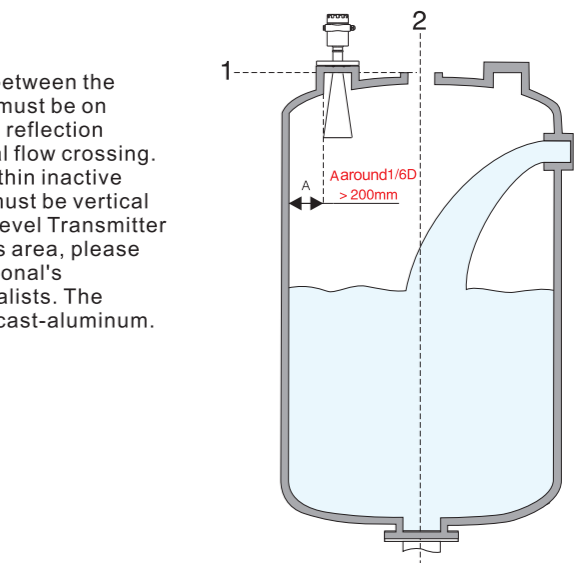

The unit measures the distance from the process connection of flange

- A. Measuring range adjustment
- B. Inactive area
- C. Upper level adjustment
- D. Lower level adjustment

Notice: the highest level value must not be in the inactive area.

The effective part of antenna is the part of horn antenna. It should completely emit outside of the tank nozzle. Various length are available.if necessary to be added the antenna extension.

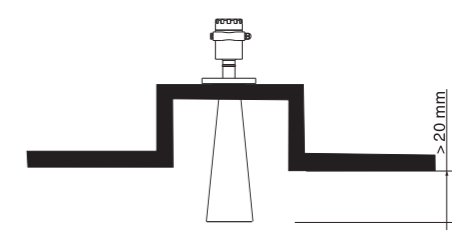

When the length of antenna is shorter than the tank fitting, it is necessary to be added the antenna extension.

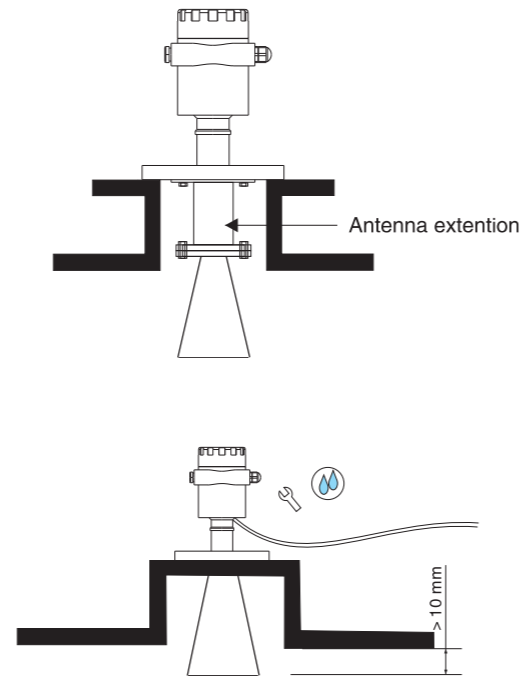
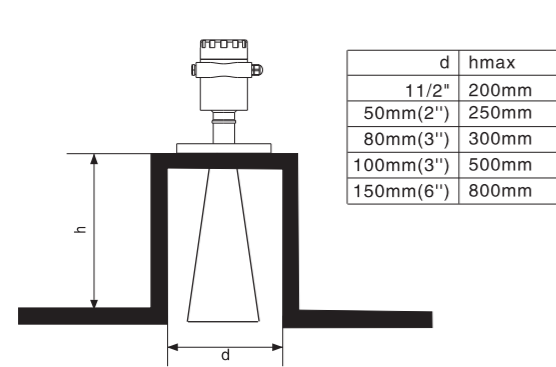

Moisture-proof

While carrying out installation indoor, indoor humidity or the panel of heating tank, it is necessary to tighten the cable gland and also bend the wire on connection. See the drawing below:

Common installation position

1. Right: sunshade and rainproof measures should be taken if installed outdoor.
2. Wrong: do not install them in the up side of the material flow to ensure they are detecting the material surface but not material flow.

3. The antenna should be vertical to material surface and avoid leaning to tank wall.
4. Wrong: The transmitter is installed in the top of arch or circular tank will cause multiple reflection, this should be avoided when install it.

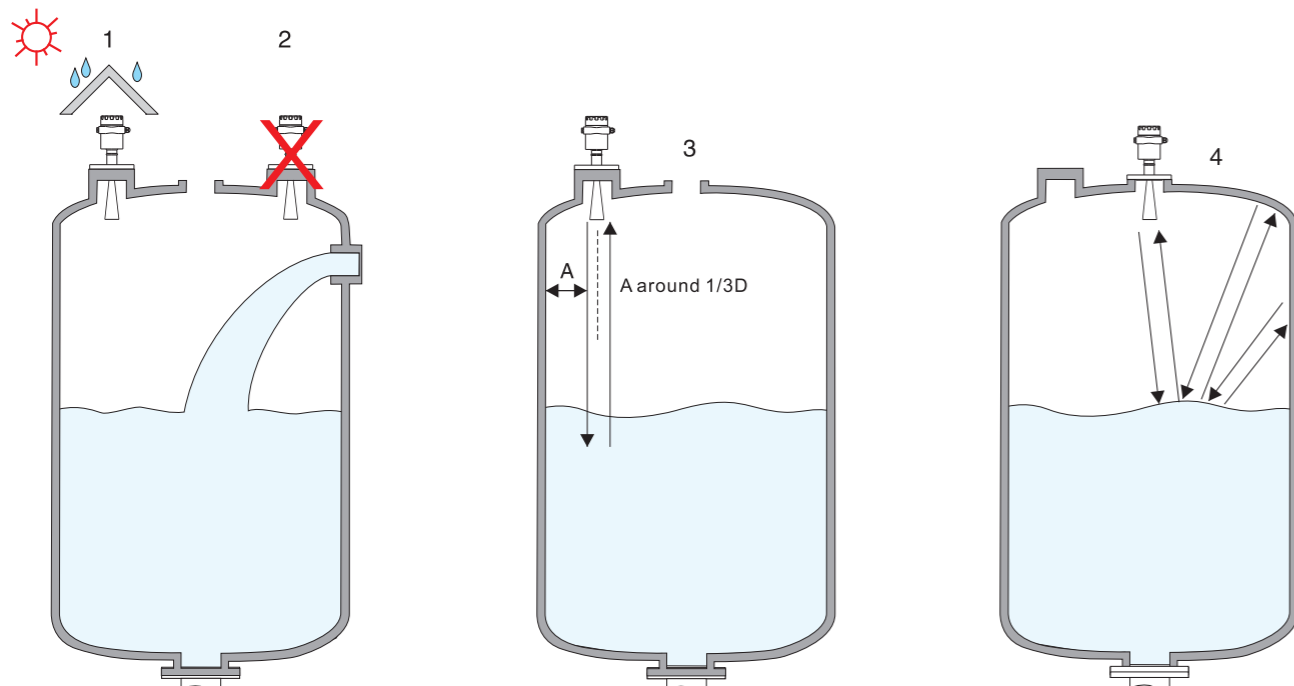

Installation of baffle-board

When there are some barriers in the tank will effect the measuring, it's better to install baffle-board to reflect the wave to other place, the device may have "Spurious wave reflection learn" if necessary.

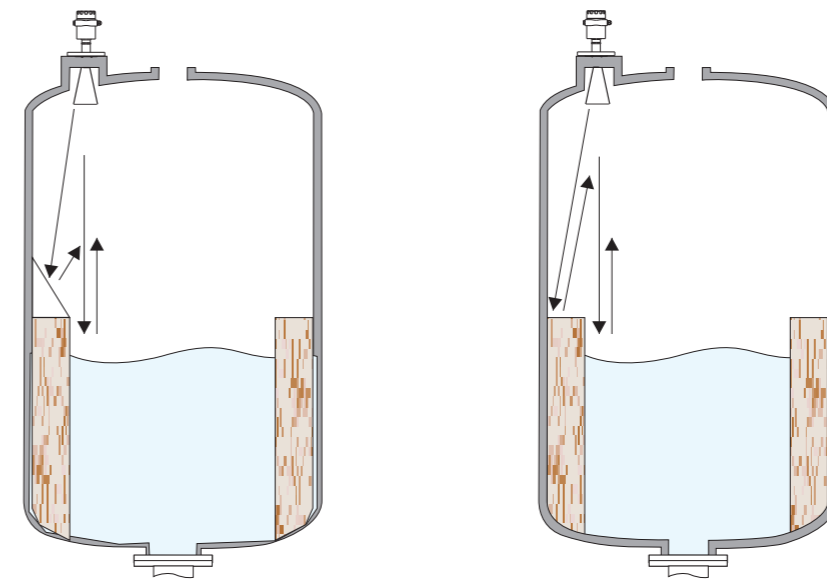

Installation of tube

If stir in the tank, the devices must far away from the stir. The device need to have "Spurious wave reflection learn" after installation to avoid the effect of spurious wave. If there are bubble or wave generated by stir, so we should use this installation.

Using tube installation will avoid the effect of barriers, bubbles and waves to measurements. Due to material input, stir or any other process in the tank, there will be some bubbles on the surface of some medium to decay signal. If the bubbles cause measurement error, we suggest to install the device in the tube, or use our guide radar level sensors.

